



# laser-based systems.

SURFACE INSPECTION  
LASER BEAM DELIVERY & CONDITIONING  
ADAPTIVE OPTICS  
LENS DESIGN  
LENS ASSEMBLY & QUALIFICATION



**DEMCON**

FOCAL

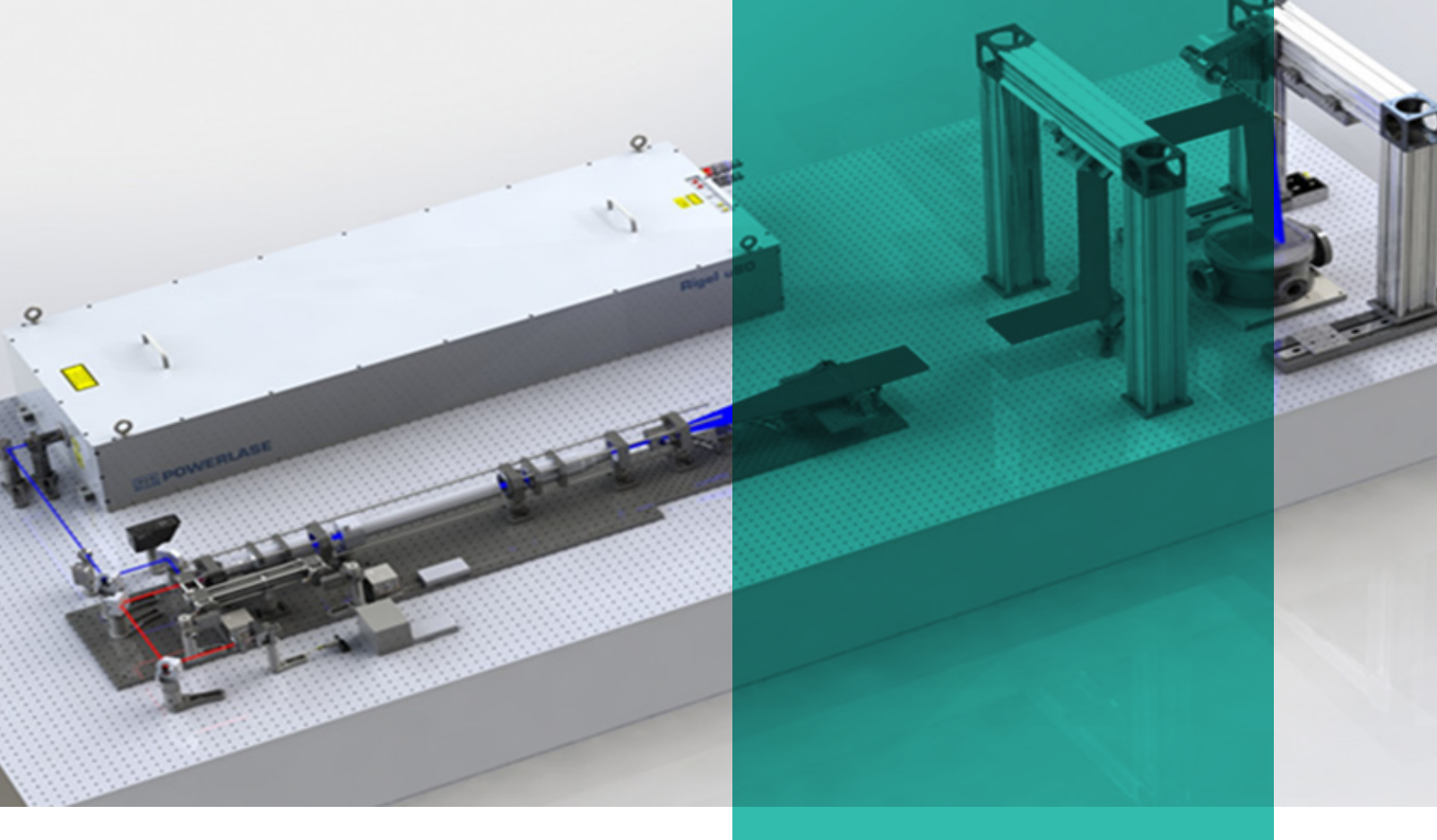

## LASER BEAM DELIVERY AND CONDITIONING

Demcon Focal provides optomechatronic solutions for beam shaping and delivery of high power laser beams with a prescribed beam-profile and alignment to a target.

Full design and integration of:

- Custom optics for beam shaping of multimode lasers
- Fine steering mirrors for active laser beam alignment

- Laser beam characterization and monitoring unit
- Opto-mechanical design for laser safety
- Software and hardware for control and synchronization of the laser and scanning system

For laser-machining applications, optical measurement systems can be integrated for sub-micron milling inspection.

## ADAPTIVE OPTICS

Within Demcon Focal we have experience with adaptive optics in different applications, like atmospheric aberration correction and lens aberration correction in metrology systems. At Demcon Focal we have built a closed-loop wavefront control system. Using a Shack Hartmann sensor in combination with in-house FPGA based electronics to control a deformable mirror we are able to shape a laser wavefront within microseconds.

Together with TNO we work on the TOMCAT project.

One of the innovative elements of TOMCAT is its ability to pre-correct the laser light with adaptive optics. When light moves between the surface of the Earth and space, it gets distorted due to the fluctuations in the atmosphere. TOMCAT measures the distortion of the received laser light from the satellite, and by applying the inverse of this distortion to the transmitted light, a robust communication link can be established. In order to enable this, high speed adaptive optics technology is required.

## LENS DESIGN

Laser annealing is growing rapidly in the semicon market. The elementary module for the laser annealing process is a laser beam delivery system that conditions the laser beam such that an uniform annealing is achieved over the surface. Demcon Focal has developed a laser annealing module in cooperation with a partnering system integrator. Our contribution:

- The development of a custom made F-theta lens with a long working distance
- Reduction of angular displacement errors due to manufacturing tolerances
- Tooling design and development for optical alignment and qualification



### Project specifics

- Focal length of 280mm
- Scan range of 7mm with  $\pm 4$  degree (Gaussian) input beams
- 500W laser with wavelength of 500 nm
- F-theta distortion less than 0.01%

## LITHOGRAPHY LENS DESIGN

Demcon Focal has the capabilities to design, deliver and qualify one of the most demanding precision optical assemblies: the lithography lens. Demcon is using state of the art alignment tooling (Opticentric) and cleanroom facilities to achieve diffraction limited imaging for a large field of view. We have designed a lithography lens with high NA and large field of view that is capable of imaging semiconductor structures on wafers to produce processors, LEDs, MEMS, USB memory, etc.

### Project specifics

- Magnification 5x (0.2x)
- Telecentric on image side
- FOV 22mm x 22 mm
- Diffraction limited
  - $CD < 0.4\mu m$  ( $NA > 0.5$ )
  - High CD uniformity ( $< 2\%$ )
- Useable DOF  $\sim 1 \mu m$
- Distortion  $< 100nm$  (maximum over field)
- Magnification needs to be adjustable using back-focus
  - Order of magnitude 10 ppm
- Minimize magnification and focus errors due to short term temperature fluctuations within  $\pm 0.1$  degree
- Magnification change and focus change due to pressure change is compensated using focus and back-focus only



# LENS ASSEMBLY AND ALIGNMENT

Creating state-of-the-art custom optics involves close collaboration between optical, opto-mechanical and mechanical engineering disciplines to design a lens system that meets its requirements. Besides theoretical expertise and powerful simulation software to test tolerances of a design, intimate knowledge of assembly equipment and its possibilities are needed to realize a prototype or produce small series optical systems against reasonable costs. Demcon Focal not only has all the theoretical expertise under one roof, it also has the facilities and hands-on assembly experience to deliver your lens system.

For various customers Demcon Focal has assembled and aligned optics, such as:

- F-theta lens with a long working distance
- Focusing lens with a Strehl ratio  $> 0,95$
- Lens systems for various microscopic applications
- Lenses for lighting applications

## Project specifics

- Alignment of optics to diameter of 100  $\mu\text{m}$
- Stacks of up to 20 lenses or more
- Use of various assembly techniques such as individual lens cells
- Decentering accuracy  $< 1 \mu\text{m}$
- Tip/tilts  $< 5$  arcseconds

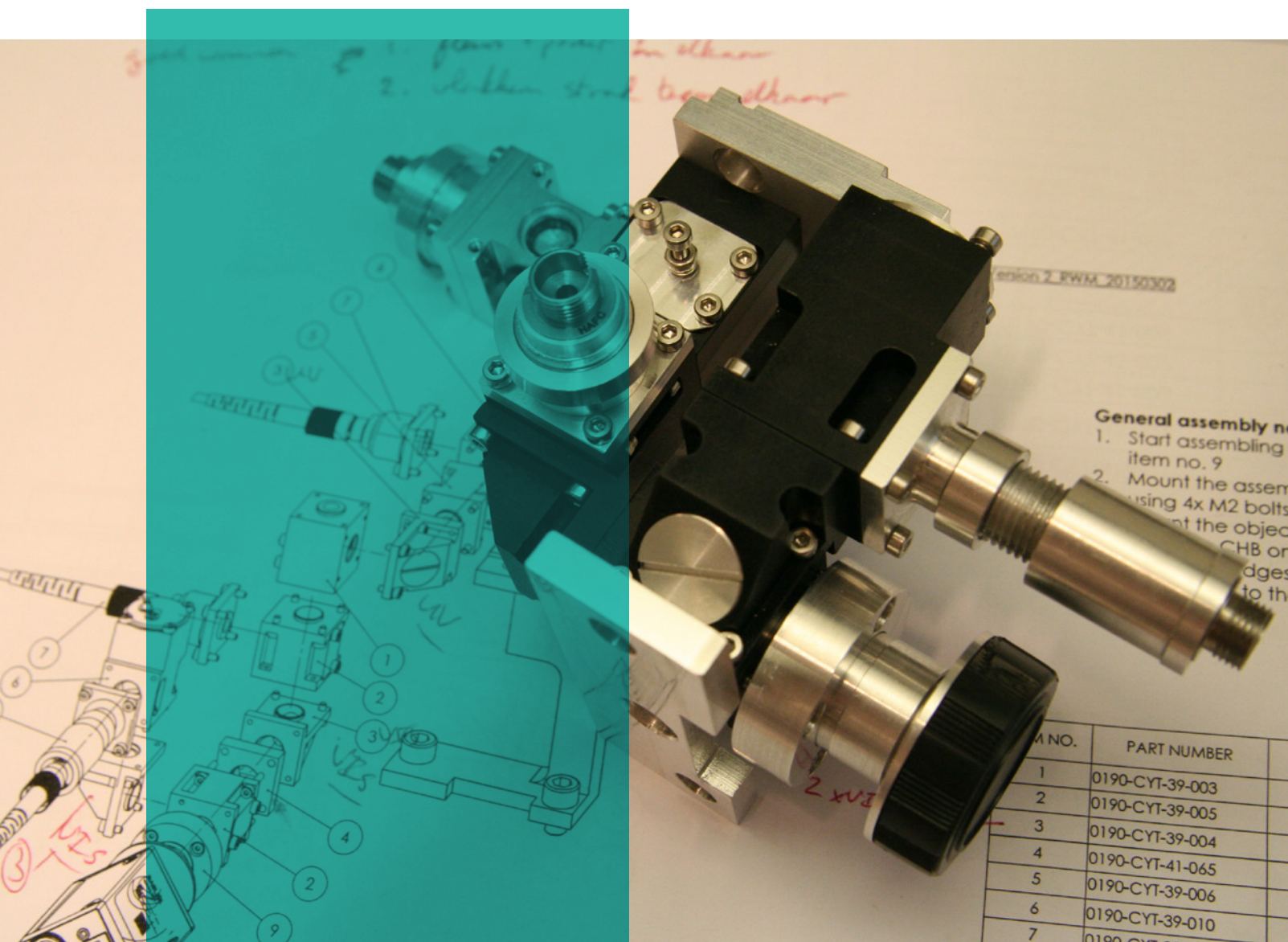

PV: 187.714  
RMS: 32.089  
mlambda (355.0 nm)  
Points: 2978344

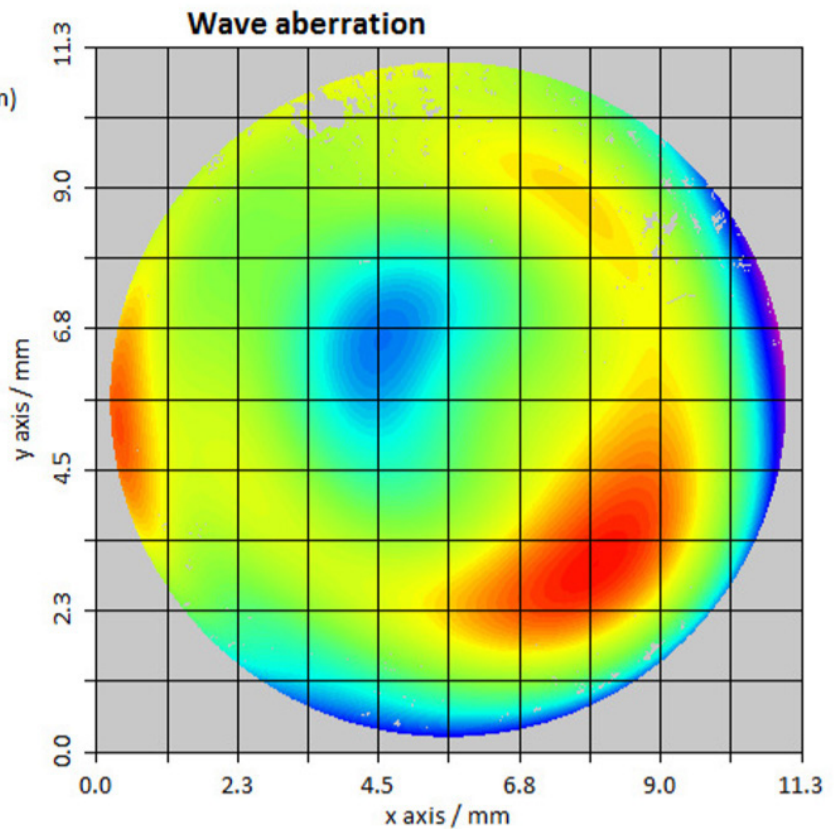
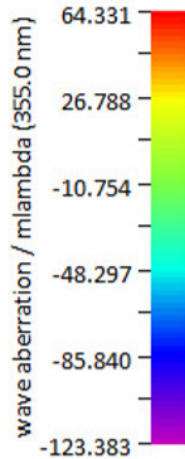

## LENS QUALIFICATION

Projects for designing and creating lenses do not stop after assembly: lenses need to be qualified and tested against customer requirements. Demcon Focal is well equipped to integrate this into any lens development project by using market standards for metrology or in various cases by creating in-house qualification systems for wave front aberrations, distortion, field curvature, MTF or other means to determine the performance of an assembled lens.

### Project specifics

- Customized interferometric double pass wave front analysis
- Distortion measurement < 100 nm
- Field curvature
- MTF values using various targets/grids
- Through focus scans
- Telecentricity

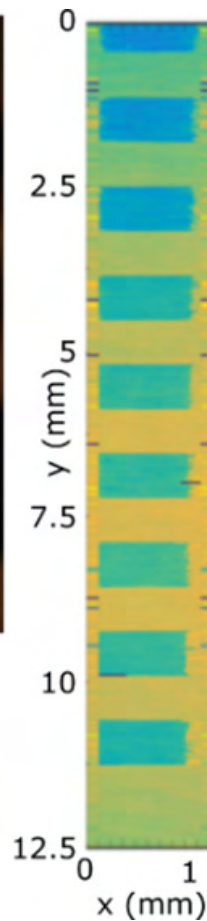
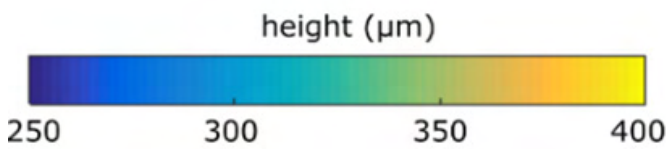
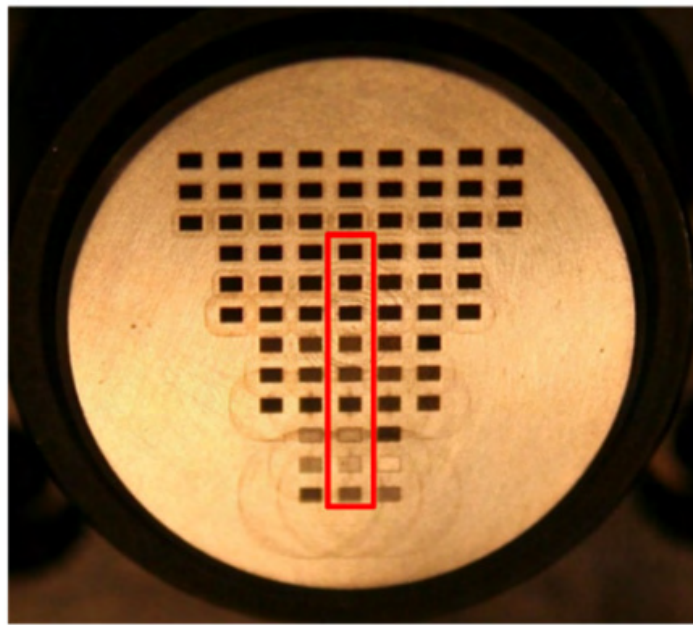

## LASER MATERIAL PROCESSING

Within the H2020 project ADALAM, a novel depth sensor was successfully integrated into a laser micromachining system. This new sensor allows the machine to get feedback on the actual machined depth, which is used to automatically adapt the micromachining process. This process results in an increased depth accuracy of the machined structures.

Demcon Focal's contribution was the development of the sensor, including the automatic reference arm and the interface with the existing micromachining system. The sensor was based on a frequency domain low coherence interferometer in the beam path of the laser micromachining system. The integrated depth sensor can be used to:

- measure the surface topography before machining, to scan for existing surface deviations that can be removed in an automatically generated machining process

- measure complex shaped objects prior to machining, to precisely align the machining pattern to the work piece
- measure the surface topography while machining a part, in order to adapt the micromachining process, leading to highly increased machining accuracies and no defects
- quickly validate results after machining

Typical specifications that have been achieved

- The measurement reproducibility is  $\pm 1.5 \mu\text{m}$
- The measurement range is  $900 \mu\text{m}$
- The exposure time at the darkest spot is near 1 ms



# OPTICS MANUFACTURING

Demcon Focal has an extended supply chain to serve you for nearly every lens challenge. From standard glass optics to customized prisms, filters or diamond turned mirrors, we can source all kinds of optical components to find a solution for your problem. Besides standard optical grade lenses, we also can supply aspherical polymer lenses, off-axis parabolic mirrors and customized coatings.

Because of this background our engineers think of innovative solutions others might not. Another aspect for prototyping is often speed. We select our suppliers on fast deliveries of prototyping samples and their ability to help us optimize our engineering solutions to create better pricing and lead times.

## Project specifics

- Lenses and plano windows from 2 up to 150 mm in materials from Schott, Ohara, Corning, Hoya
- Doublets and triplets, round, square, rectangular, etc.
- Prisms, cylinders
- Diamond turned mirrors, diameters up to 300 mm,  $R_a < 6 \text{ nm}$  in Alu, Cu, RSA, brass and other non ferro materials
- Infrared lenses in silicon and germanium
- Polymer lenses in Zeonex, OKP, APL, PMMA, PC
- Diffractives, Fresnels, off-axis parabolic, aspherical
- Various AR and Reflective coatings

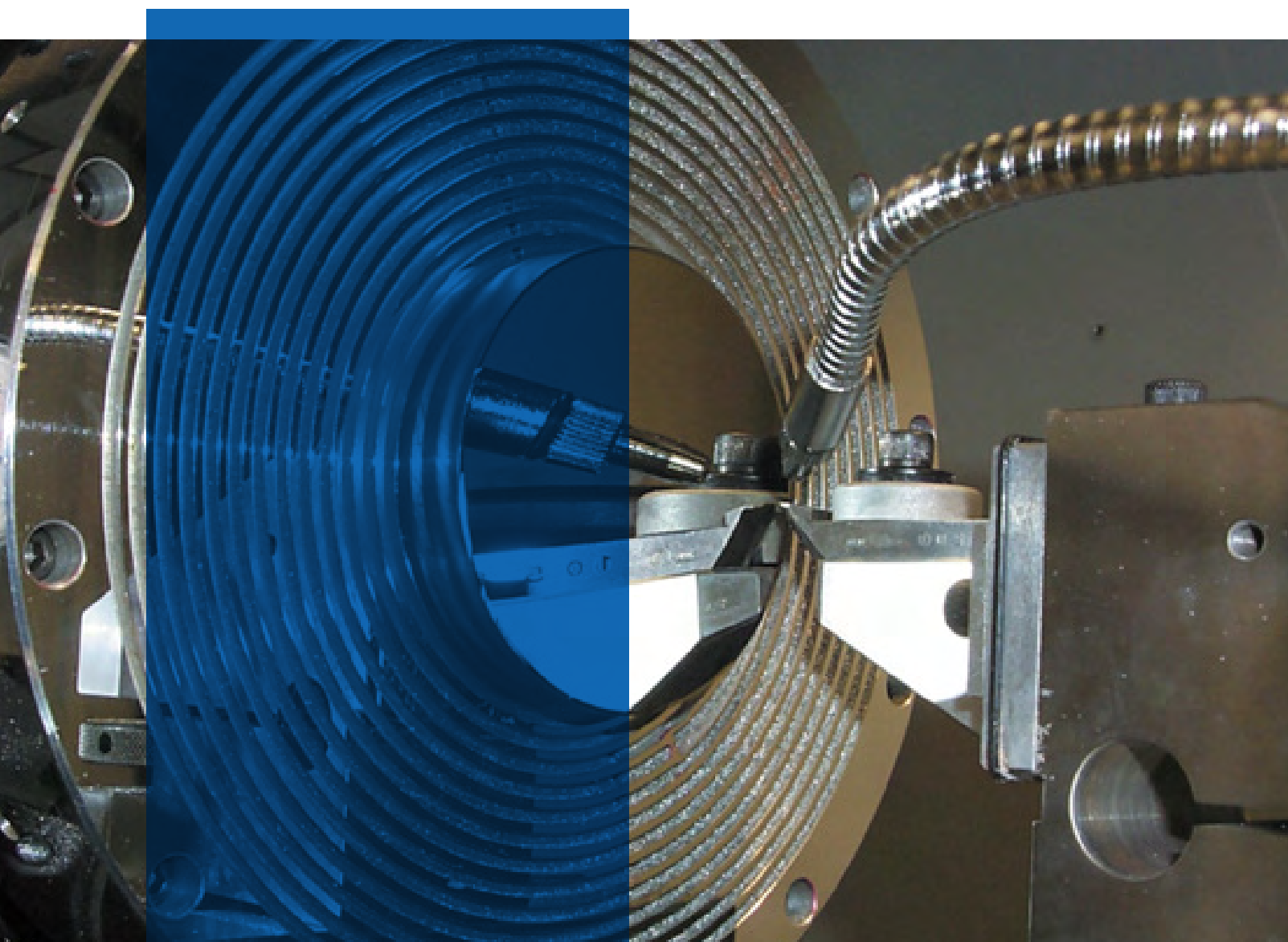

## imagine tomorrow. challenge today.

Demcon Focal is part of the international Demcon group and is specialized in design, engineering and assembly of bespoke opto-mechatronic (sub-) systems, for high technological markets like semicon, bio-medical, life science, aerospace, industrial manufacturing and others. Often these systems are used in applications where accuracy, stability and rapid movement or exploitation in extreme environments is required.

Demcon Focal achieves customized design and engineering in a multidisciplinary approach, entailing optical, vision, data, electronic, software, mechanical and system engineering. Activities include high-level requirement engineering, concept optical design, prototyping, detailed engineering, system integration, manufacturing and testing activities.

Demcon Focal also performs specialized volume production that requires trained engineers, dedicated equipment and clean environment. We can offer system service and support and have production facilities available for complex optical modules.

Institutenweg 25  
7521 PH Enschede  
The Netherlands

Kanaaldijk 29  
5683 CR Best  
The Netherlands

Delftechpark 23  
2628 XJ Delft  
The Netherlands

Zernikelaan 6  
9747 AA Groningen  
The Netherlands

Wilhelm-Schickard-Straße 6  
48149 Münster  
Germany

25 International Business Park  
#03-60A Singapore 609916

[www.demcon.com](http://www.demcon.com)  
[www.demcon.com/focal](http://www.demcon.com/focal)



FOCAL